

Angriffshemmende Verglasungen; Prüfung auf
durchwurfschützende Eigenschaft und Klasseneinteilung

Supersedes June 1984 edition.

Dimensions in mm

1 Scope and field of application

The method described in this standard serves to test the resistance of security glazing to impact and to classify glazing according to its resistance to such impact.

Note. Impact-resistant glazing is also resistant to fracture; however, its resistance class is below class B1 as defined in DIN 52 290 Part 3.

2 Concepts

See DIN 52 290 Part 1 for concepts.

3 Principle

A steel ball is dropped three times onto a test piece. It is checked whether the ball penetrates the test piece. Glazing is then classified according to its impact resistance established on the basis of test results.

4 Designation

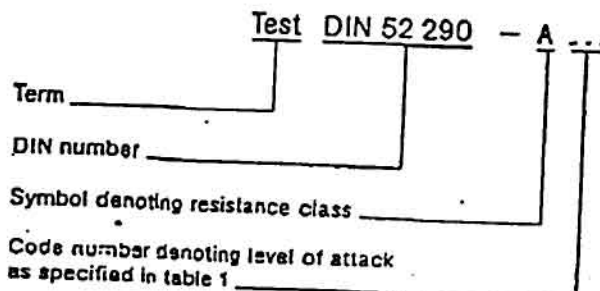

5 Apparatus

The following apparatus are required.

5.1 Falling body

A steel ball complying with DIN 5401, with a nominal diameter of 100 mm (with a mass of about 4110 g), class VI or VII.

5.2 Ball holder

A device to hold the steel ball in place before it is dropped (e.g. an electromagnet). The device shall permit the drop height to be adjusted within the specified tolerance (see table 1) and shall not exert a propelling force on the ball as it falls, i.e. the ball shall accelerate only due to gravity and fall vertically (see also subclause 7.2).

5.3 Test piece holder

The test piece holder (see figure 1) shall consist of a steel clamping frame and a catch box for splinters and the ball. The holder shall

- be rigid;
- be inflexibly connected to a rigid base;
- ensure that the test piece is uniformly clamped in a horizontal position;
- be designed so that the test piece is only supported by the clamping frame during the test;
- permit the test piece to be clamped on all sides, the clamping width being (30 ± 5) mm;
- have upper and lower clamping faces fitted with a 30 mm wide, 4 mm thick rubber strip having an IRHD hardness of (50 ± 10) as specified in DIN 53 519 Part 2;
- ensure that the test piece is clamped with a surface pressure of (14 ± 2) N/cm²;
- have an energy-absorbing catch box such that the ball is not damaged and does not rebound, should it strike it.

No part of this standard may be reproduced without the prior permission of DIN Deutsches Institut für Normung e. V., Berlin. In case of doubt, the German-language original should be consulted for the authoritative text.

Continued on pages 2 and 3

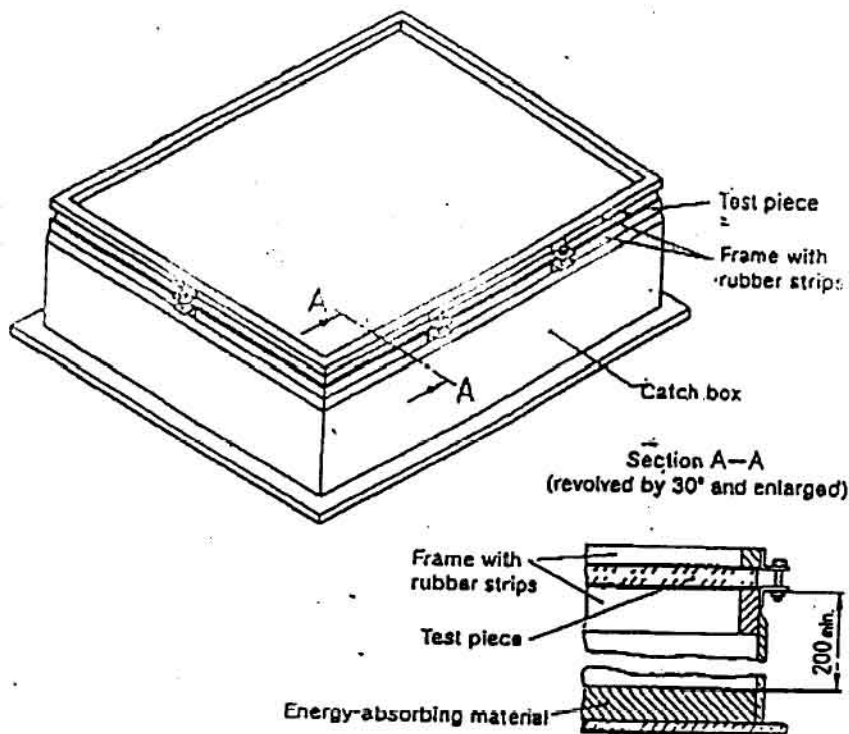

Figure 1. Example of a test piece holder

6 Test pieces

6.1 Type, dimensions and marking of test pieces

Test pieces, (1100 ± 5) mm long and (900 ± 5) mm wide, shall be prepared from the same materials, and processed under the same conditions, as the glazing which they represent. They shall be edged (see DIN 1249 Part 11).

A marking on the test piece shall indicate the side to face the impact.

6.2 Number of test pieces

Three test pieces shall be used per type of glazing and level of attack.

6.3 Conditioning of test pieces

The test pieces shall be conditioned in a vertical position, at a temperature of $(23 \pm 2)^\circ\text{C}$, for at least 12 hours immediately prior to testing.

7 Procedure

7.1 Testing shall be carried out at a temperature of $(23 \pm 2)^\circ\text{C}$.

7.2 The test piece shall be placed horizontally in the test piece holder. The drop height (clear distance between falling body and test piece) shall be adjusted to comply with the specifications given in table 1.

Table 1. Drop heights

| Level of attack | Drop height, in mm, (± 50) |
|-----------------|--------------------------------|
| 1 | 3500 |
| 2 | 6500 |
| 3 | 9500 |

7.3 The ball shall be dropped three times onto each test piece from the same height. The drop shall be made to form an equilateral triangle, in the centre of the test piece, with a side length of (130 ± 20) mm. Any loose splinters shall be removed from the test piece after each drop.

8 Evaluation

8.1 Inspection for penetration and dislodgement

After testing, each test piece shall be inspected for penetration or, if no penetration has occurred, for dislodgement from the frame. A test piece shall be deemed to have been penetrated if at least one ball has passed through it.

A test piece shall be deemed to have been dislodged from the frame if one of its edges has been displaced by more than 5 mm. If so, the test shall be repeated with a new test piece.

8.2 Establishing impact resistance class

The resistance to impact of each test piece, for each level of attack, shall be established in accordance with table 2 on the basis of the evaluation described in subclause 8.1.

Table 2. Impact resistance classes

| Level of attack | Impact resistance class |
|-----------------|--|
| | None of the three test pieces was penetrated by the ball or dislodged from the frame |
| 1 | A1 |
| 2 | A2 |
| 3 | A3 |

Table 2 specifies three resistance classes. The resistance class increases as the level of attack increases (i.e. greater drop heights are used).

The glazing shall be classified according to the lowest class for which test conditions have been met.

- b) sampling procedure;
- c) level of attack tested, as specified in table 1;
- d) designation of the resistance class of the glazing type, e.g. Glazing DIN 52 290 - A2 (cf. clause 4);
- e) date of test.

9 Test report

The test report shall include a reference to this standard and provide the following information:

- a) type of glazing (as stated by the manufacturer);

Standards referred to

| | |
|-------------------|---|
| DIN 1249 Part 11 | Flat glass for building construction; glass edges; concept, edge types and finishes |
| DIN 5401 | Rolling bearing components; balls |
| DIN 52 290 Part 1 | Security glazing; concepts |
| DIN 52 290 Part 3 | Testing of security glazing for resistance to fracture by a cutting tool |
| DIN 53 519 Part 2 | Testing of elastomers; determination of indentation hardness of soft rubber; International Rubber Hardness Degree (IRHD); hardness testing of specimens of small dimensions |

Other relevant standards

| | |
|-------------------|--|
| DIN 52 290 Part 2 | Testing of security glazing for bullet resistance |
| DIN 52 290 Part 5 | Testing of security glazing for resistance to explosives |

Previous edition

DIN 52 290 Part 4: 06.84.

Amendments

The following amendments have been made to the June 1984 edition.

- a) The specifications given in DIN 52 290 Part 1 have been taken into consideration.
- b) Details of the fast piece holder have been amended.
- c) In figure 1, the distance between test piece and energy-absorbing material has been specified.
- d) The limit deviations for the drop height (table 1) have been changed from ± 10 mm' to ± 50 mm'.
- e) The standard has been editorially revised.

Explanatory notes

This standard has been jointly prepared by Technical Committee 385 *Prüfung von Sicherheits-Sonderverglasungen* of the *Normenausschuß Materialprüfung* (Materials Testing Standards Committee), Technical Committee *Glas*, *Normenausschuß Bauwesen* (Building and Civil Engineering Standards Committee) and *Normenausschuß Kunststoffe* (Plastics Standards Committee) of DIN.

The resistance classes defined here may not be suitable for all applications. The user should consult with experts, if necessary, and specify the requirements to meet the particular application.

International Patent Classification

G 01 N 33/38